



12" Dual Port

Flanged CL 150 – 600



12" Dual Port Flowgrid® Valve with Series 20 Pilot

SECTIONAL VIEW

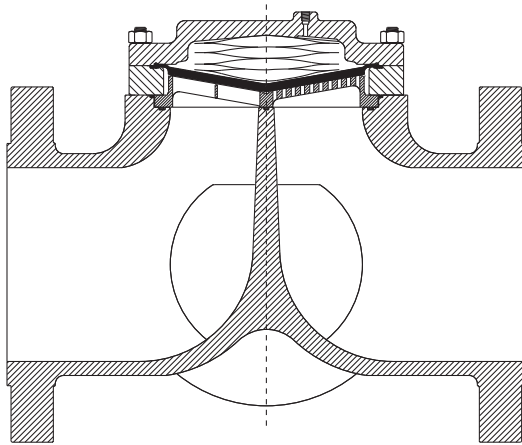

OVERPRESSURE PROTECTION

The Flowgrid® Valve is bi-directional and has a full ANSI rating on both the inlet and outlet. Overpressure protection is required only if the pressure can exceed the flange or body rating.

The pilots, like most regulators, may have an outlet pressure rating lower than the inlet pressure rating. If this is the case then some external form of overpressure protection must be provided for the pilot.

Anytime the Flowgrid® valve or pilot system is exposed to pressure in excess of its rating it should be inspected for damage.

The 12" Dual Port V-6 Flowgrid® Valve is an economical and easy to maintain pilot operated valve for both gas and liquid applications. The valve can be used with dual pilots for redundant control (acts as two regulators in parallel), but is primarily a large capacity valve that can be maintained by one person. The ports are mounted at 45 degree angles for easy in line maintenance. The low profile and easy in line maintenance makes it ideal for skid mounted, vault, and enclosure installations.

SPECIFICATIONS

Size	12"
Body Style	Dual Port (8")
End Connections	12" CL150, 300, 600 Flanged
Temperature	Working -20°F to 150°F Emergency -40°F to 175°F
Max. Operating Differential	800 psi
Max. Emergency Differential	1000 psi
Min. Differential	Refer to graph on page 2
Cracking Differential	Refer to graph on page 2
Max. Inlet Pressure	1480 psig*
Outlet Pressure Range	Limited By Pilot
Flow Direction	Bi-Directional**
Body Taps	Four 1/4" - 18NPT

* Limited by pilot or flange rating

** Reverse flow by changing pilot connections and reversing spring case

MATERIALS OF CONSTRUCTION

Body & Spring Case	ASTM A 216 GR WCB Carbon Steel
Throttle Plate	17 - 4PH Stainless Steel
Diaphragm	Nitrile/Nylon*
O-Ring & Seals	Nitrile
Bolting	ASTM A 193 GR B-7 or Equal
Spring	301 Stainless Steel

*Refer to diaphragm selection chart on page 2

STOCK NUMBERS

12" Dual Port Valve	Stock #	Weight
150# Flange	FG-74	1100 lbs.
300# Flange	FG-75	1200 lbs.
600# Flange	FG-81	1400 lbs.

DIMENSIONS

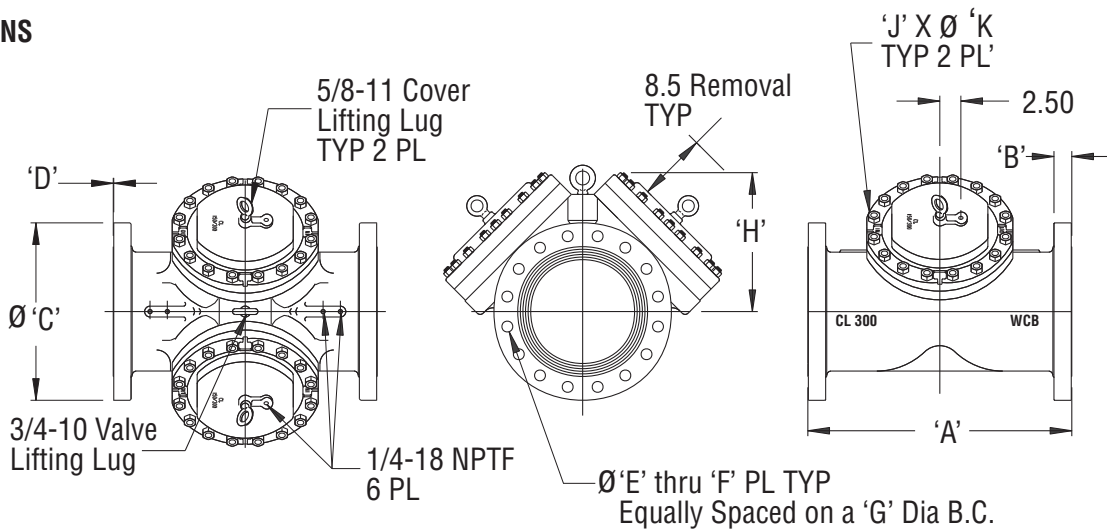

End Connection	A	B	C	D	E	F	G	H	J	K
150# Flange	29.00	1.25	19.00	0.062	1.00	12	17.00	16.50	16	.75 - 10 UNC-2B
300# Flange	30.50	2.00	20.50	0.062	1.25	16	17.75	16.50	16	.75 - 10 UNC-2B
600# Flange	32.25	2.88	22.00	0.250	1.38	20	19.25	17.00	24	.875 - 9 UNC-2B

FLOW COEFFICIENTS AND CONSTANTS

12" Dual Port Valve				Swage Factor	
Percent Capacity	Cv	C1	Cg	1.5:1	2:1
100%	1060	38	40400	0.97	0.95
75%	1030	30	30400	0.98	0.96
50%	700	29	20000	0.99	0.98
35%	500	28	14200	1.00	1.00

NOTE: Allow a 5% factor of safety when calculating relief capacity

MINIMUM PRESSURE DIFFERENTIAL VS. CAPACITY

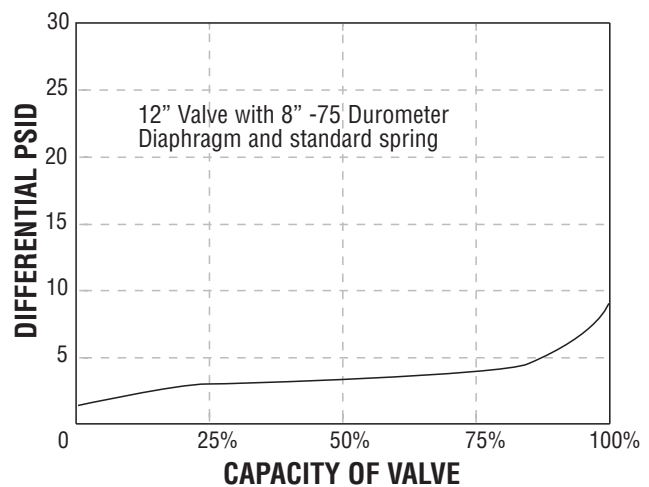

DIAPHRAGM SELECTION

Compound	Temp. Range (Degrees F)	Maximum Differential	Characteristics	Recommended Applications
75 Duro	-20 to 150	1000 psid	Best All Around Material	60 psid to Max. Differential
60 Duro	-25 to 150	300 psid	Best Shutoff at Low Differential Pressure	Low Differential (100 psid or less) or Low Temperature
80 Duro High ACN	-5 to 175	1000 psid	Higher Abrasion and Swelling Resistance	High Differential (400 psid or higher) or Abrasive Conditions with Distillates
80 Duro Low ACN	-20 to 150	1000 psid	Higher Abrasion Resistance and Low Temperature Flexibility	High Differential (400 psid or higher) or Abrasive Conditions at Low Temperatures